

## Drying Building Materials in a Drum Dryer

Mirsharipov Rakhmatillo Khabibullaevich

Fergana Polytechnic Institute, Fergana, Uzbekistan

**Abstract;** The article provides an analysis of the raw materials of construction materials in the drying stages of the processing in rotary drum dryers and taking into account the amount of convective heat passing through the metal parts of the drum during drying.

**Keywords:** Drum drying, disperse material, contact heat, glass raw material.

The intensive development of the construction industry in our country is accompanied by a sharp increase in demand for glass products, as well as the demand for its quality. As a result, it leads to increased competition among manufacturers and modernization of production processes. One way to reduce product cost is to optimize energy-intensive processes. One of such processes in the glass industry is the processing of raw materials in drying drums. A large amount of energy is used to evaporate the liquid in the raw material. Therefore, the analysis of the operating modes of the existing drying drums, increasing the energy efficiency of the apparatus by selecting the optimal modes of the drying process is an urgent task.

The analysis of theoretical descriptions of heat and metabolic processes and methods of research of drying processes allowed to develop the basics of laboratory equipment, proposals for the intensification and management of processes. Research on heat and metabolic processes in drying drums allows to fully cover various aspects of changes in the characteristics and kinetics of drying taking place in the apparatus. To create a mathematical model of this process, the temperature rise of the material in the drying stages, the evaporation cycles of unbound free and bound moisture, the equilibrium of the drying agent with the wet material, the heat received from the heating air from the structural elements of the drum must take into account the additional heat transferred to the material and the mixing of the drying agent material. To do this, the process must be considered separately at each stage of drying. In the first stage of drying, the drying agent is saturated on the surface of the material, and the evaporation of moisture from the surface of the material takes place according to the laws of transition of the free liquid to the vapor state. In this case, the speed of the drying process is determined by the amount of heat passed from the heat-drying agent by convection to the wet material. the evaporation of moisture from the surface of the material takes place according to the laws of transition of the free liquid to the vapor state. In this case, the speed of the drying process is determined by the amount of heat passed from the heat-drying agent by convection to the wet material. the evaporation of moisture from the surface of the material takes place according to the laws of transition of the free liquid to the vapor state. In this case, the speed of the drying process is determined by the amount of heat passed from the heat-drying agent by convection to the wet material.

### Object and method of research.

It is known that there are two types of heat exchange in a drum dryer - contact and convective methods. However, a large amount of heat transferred to the dried material is carried out by convective heat exchange. The amount of heat transferred by convective method to the material to be dried in a drum dryer is up to 20 times higher than the amount of heat transferred by the contact

method. The intensity of convective heat transfer in a drum dryer, in turn, is directly related to the opening of the particle surface. The more the material spreads across the drum surface, the larger the surface area of the open particles for convective heat exchange. Summarizing the above, we see that the drying efficiency of mineral fertilizers in a drum dryer depends significantly on the uniformity and surface of the curtain of dried material falling from the nozzles of the inner drum devices. Ensuring that the surface of the particles is scattered along the drum section is the main purpose of the drum internal devices (nozzles) [2]. Based on the above, in order to intensify the drying process of superphosphate fertilizer and increase the heat exchange surfaces, a design scheme of the nozzle forming the heat exchange surfaces was developed and a laboratory version of the dryer was created [6]. Figure 1 shows an overview of the experimental device. Based on the above, in order to intensify the drying process of superphosphate fertilizer and increase the heat exchange surfaces, a design scheme of the nozzle forming the heat exchange surfaces was developed and a laboratory version of the dryer was created [6]. Figure 1 shows an overview of the experimental device. Based on the above, in order to intensify the drying process of superphosphate fertilizer and increase the heat exchange surfaces, a design scheme of the nozzle forming the heat exchange surfaces was developed and a laboratory version of the dryer was created [6]. Figure 1 shows an overview of the experimental device.

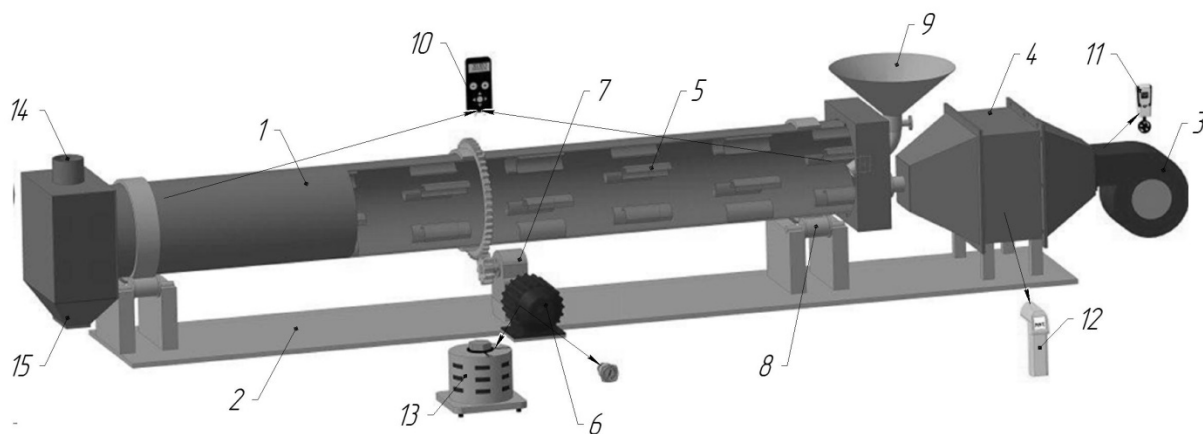

**Figure 1. Schematic of an experimental device.**

*1-dryer body; 2- floor; 3-fan; 4-calorifier; 5-nozzle;v6-electric motor; 7-reducer; 8- base rollers; 9-product bunker;v10-electronic pressure gauge; 11-anemometer; 12-electron thermometer; 13-LATR; 14-chimney pipe; 15- product unloading bunker.*

Studies were performed on an experimental device (Fig. 1) to verify the adequacy of the proposed model with a real drying process. The results obtained showed that the proposed mathematical model was consistent with the experimental results.

One of the important parameters that determines the speed of the process in the drying drum is the temperature of the drying agent. During continuous drying, the temperature of the drying agent decreases along the length of the apparatus due to the heat transfer to the material, the drum blades and the wall.

During the evaporation of the second bound moisture of the drying, dry areas are formed on the outer surface of the material, the relative humidity of the drying agent on the surface of the material suddenly decreases. As a result, the surface temperature of the material increases and its value is calculated by the equilibrium of the material to be dried with the drying agent.

With the hot wall of the drum and the shovels, under the influence of heat of the grains of material, dried surfaces are formed on its outer layer, and its size and thickness increase along the length of the drum. The dried material is similar to hot-insulating materials in terms of its thermal conductivity. As a result, the main resistance to the heat exchange process is the dried surface of the material, where the same layer forms the surface of the heat exchange process. The processes taking place in this zone are determined by the Lykov criterion. At small values of the Lykov number, the liquid does not have time to rise to the surface of the particle in the inner layers of the material, and a layer of dry material is formed on its outer surface. This layer is formed between the heat exchange surface and the evaporation surface.

The material to be dried in the drum apparatus is sprayed from the top shovel to the bottom or bottom of the drum, and the remaining material remains stuck in the shovels (Fig. 2). In the contact zone, heat exchange takes place on the surface of this material and the process of building the particle from the outer layer takes place. Until the next rotation of the drum, all the particles in this layer are in contact with the heated elements of the drum. Since this contact time is much smaller than the total time the material is in the drum, we use short-term contact theory to mathematically model the process of heat exchange within the layer.

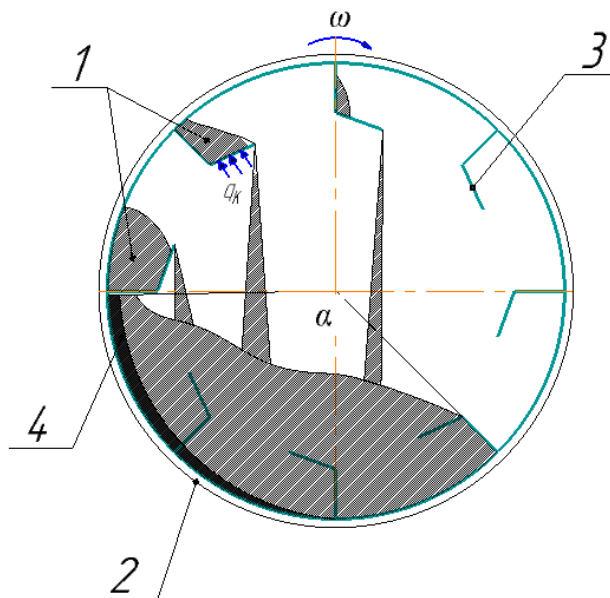

**Figure 2. Scheme of placement of the material during drying.**

1 - wet material, 2 - drum wall, 3 - shovels, 4 - dry material.

In addition to the convective energy received by the particles from the heated air during the heat exchange process in the drying drum, the amount of contact heat received by the material particles from the metal elements of the apparatus must be taken into account. Assuming the external shape of the particles to be dried as a straight sphere, we assume that the amount of additional heat passing through the metal parts of the apparatus in terms of thermal conductivity to the particle is  $Q_k$ . In this case, we find the change in the value of  $Q_k$  according to Fure's law from the following equation:

$$q_k = - \frac{\lambda_M \left( \frac{\partial t_M}{\partial R} \right)_s ds \cdot d\tau}{d^2 Gc} \cdot (1)$$

here:  $\lambda_M$  - thermal conductivity of the material;  $t_M$  - material temperature;  $R$  - particle radius,  $S$  - surface,  $\tau$  - time,  $G$  - amount of material.

To determine the temperature gradient on the surface of a spherical particle, it is necessary to know the change in the thickness of the particle. This value is found by the differential equation of thermal conductivity.

$$\frac{\partial t_M}{\partial \tau} = a \left( \frac{\partial^2 t_M}{\partial R^2} + \frac{2}{R} \cdot \frac{\partial t_M}{\partial R} \right), (2)$$

The initial conditions of this equation are:

$$\tau = 0 \text{ б\ddot{y}лганда } t_M = \text{const} \text{ and } \tau > 0 \text{ б\ddot{y}лганда } t_M = f(R) \text{ and boundary conditions: } t_M^{\text{surface}} = t_{\text{m\ddot{y}i}} \text{ and } \left( \frac{\partial t_M}{\partial R} \right)_{R=0} = 0.$$

here:  $R$  - particle radius,  $t_M^{\text{surface}}$  - surface temperature of the material,  $t_{\text{toi}}$  - saturation temperature of water vapor at the pressure inside the apparatus.

This equation was solved by a numerical method of solving differential equations.

When analyzing the trajectory of the material particles in the drying drum, this process can be compared to the molecular diffusion process based on the analysis of the movements in the flow structure. This similarity has also been noted by many researchers. Therefore, we consider the motion of the material in the drying drum according to the diffusion model and use the equations of molecular diffusion processes. One such parameter in the mass transfer property is the longitudinal mixing coefficient. This coefficient is similar to the molecular diffusion coefficient. By calculating the mass transfer and heat transfer processes similarly, we assume a longitudinal heat mixing coefficient similar to the longitudinal mixing coefficient for the heat exchange process.

The diffusion model of heat transfer in the electromotive part of the drying agent hardware length is as follows:

This equation gives a differential view of the variation of the drying agent temperature along the length of the apparatus at the expense of mixing. To solve this equation, it is necessary to determine the temperature change of the material along the length of the apparatus during drying. We therefore use numerical methods to solve this differential equation. In doing so, we assume that the physical properties of the material do not change over a given part. Furthermore, since the change in temperature and humidity of the drying agent in this obtained part is small, we consider their linear rate of change to be constant. We will go step by step the numerical method of solving the equation. That is, the boundary conditions are given only the initial temperature at the beginning of drying. Therefore, the temperature change at each step was compared with the experimental results. until we reach the desired accuracy. The method of solving this numerical differential equation can also be used when we obtain the motion of the drying agent by the ideal compression method.

Modeling of the drying process is calculated in the same step for all elements of the drum. In this case, the value of the step depends on the length of the drum and the number of elements received.

## References:

1. Тожиев, Р. Ж., Ахунбаев, А. А., & Миршарипов, Р. Х. (2018). Сушка тонкодисперсных материалов в безуносной роторно-барабанном аппарате. Научно-технический журнал ФерПИ,-Фергана, (2), 116-119.
2. Тожиев Р. Ж. и др. Оптимизация конструкции сушильного барабана на основе системного анализа процесса //Universum: технические науки. – 2020. – №. 11-1 (80).
3. Тожиев, Р. Ж., Ахунбаев, А. А., Миршарипов, Р. Х., Муллажонова, М. М. К., & Йигиталиев, М. М. У. (2021). АНАЛИЗ ПРОЦЕССА СУШКИ МИНЕРАЛЬНЫХ УДОБРЕНИЙ В БАРАБАННОМ АППАРАТЕ. Universum: технические науки, (8-1 (89)), 31-36.
4. Ахунбоев, Адил Алимович; Хабибуллаевич, Миршарипов Рахматилло. Барабанли аппаратда дисперс материални куритиш жараёни статикаси. 2020. Фарғона политехника институти Илмий-техника журнали.5, 1.268-272.
5. Mirsharipov, R. H., & Akhunbaev, A. A. (2020). Research of Hydrodynamic Parameters of Drum Dryer. International Journal of Advanced Research in Science, Engineering and Technology, 7(11).
6. Tojiyev, R. J., Akhunbaev, A. A., & Mirsharipov, R. X. (2021). RESEARCH OF HYDRODYNAMIC PROCESSES WHEN DRYING MINERAL FERTILIZERS IN DRUM DRYERS. Scientific-technical journal, 4(4), 10-16.