

Technological Methods of Digital Reconstruction of Complex Mine Cracks are the Use of Technological Processes in Mining

*Allambergenova Mexribanu Mirzabek qizi, Kulmuratova Aliya Janabay qizi,
Shukirallaev Mansur Nasirulla o'g'li, Begmuratova Shaxnoza Dauletbay qizi*
Student of Nukus Mining Institute

Abstract: Visualization of complex geological structures can technically support the accurate prediction and prevention of coal mine disasters. This study proposed a new digital reconstruction method to visualize geological structures based on establishing a virtual model in the digital twin system. This methodology for the digital reconstruction of complex fault structures comprises the following four aspects: collection and fidelity of multi-physical field data of the fault structures, the transmission of multi-physical field data, the normalization of multi-physical field data, and digital model reconstruction of fault structures. The key scientific issues of this methodology to be resolved include in situ fidelity of multi-field data and normalized programming of multi-source data. In addition, according to the geological background and conditions in Da'anshan coal mine in western Beijing, China, a preliminary attempt is made to reconstruct a digital model of fault and fold structures using the methodology proposed in this study.

Keywords: Digital reconstruction • Fault structure • Multi-physical field • Data collection and fidelity.

Introduction

Owing to the continuously increasing the depth and intensity of coal mining, coal bursts have become a major dynamic disaster in global underground coal mining ;There are numerous causes of coal burst accidents, with complex geological structures (primarily faults, folds, and phase transitions) being one of the most studied. According to statistics, coal bursts that occur near geological structures account for more than 70% of all coal burst accidents. Predicting the occurrence of tectonically induced coal bursts can be greatly aided if geological structure can be effectively digitized. In fact, numerous investigations have been performed to focus on the studies of the geological structure formation mechanism, stress distribution around the structures, and the criteria for the activation of geological structures. Using the developed geological experimental system, investigated the development process of reverse faults as well as the evolution of stress and deformation of the hanging wall. The findings show that the dip angle of reverse faults is primarily determined via rock properties, whereas the drop is primarily determined via horizontal stress. adopted the field measurement analysis, theoretical analysis and numerical simulation to study the stress distribution of overlying rock structures and the occurrence mechanism of coal bursts during the mining process of mining face under the condition of large fault. used physical and numerical simulation to investigate the evolution characteristics of the stress field on the fault slip surface and the precursor information of fault slip and instability when mining disturbance occurred on the mining face. studied the unloading effect of thrust fault caused by mining disturbance utilizing physical and numerical simulation and clarified the mode as well as process of unloading instability of thrust fault in Yima mining area. proposed a mechanical model to calculate the stress distribution on fault surfaces and illustrate the fault slip characteristics. However,

the traditional research methods can not accurately obtain the multi-physical field's evolution of complex fault geology in three dimensions. The main limitation for accurate prediction of coal bursts is a lack of understanding of geological conditions and the unknown evolution process of multi-physical fields. With the rapid development of information and communication technology in recent years, the industrial digital transformation has been accelerated by increasing modern industries. Digitization refers to introducing complex and variable information in the physical world into the computer and forming identifiable, storable and computable data using the information system, various sensors, machine vision and communication technologies. These data are used to perform the unified processing, analysis, visualization and application. In the application of digital technologies, the digital twin system provides a new approach for the reconstruction and visualization of multi-physical fields of complex fault structures. Moreover, this system developed based on the digital approach is a new generation of information technology and covers the entire cycle, the entire process, and all elements of the project, acting as a bridge and link between the physical and information world. This system includes three modules: physical model, virtual model, and information mutual feed interface between physical and virtual model. The conceptual diagram is shown in Fig. 1. The digital twin system provides users with real-time dynamic visual models based on the data drive, allowing users to have a profound and detailed understanding of the current health state of the system, and assisting users to make decisions through data analysis, iterative optimization and reverse control. Digital twin system is a widely used technology and system in aerospace, advanced manufacturing, engineering and construction. Airbus uses the digital twin system in its aircraft assembly process to increase automation and reduce lead times. Siemens developed a system model of the manufacturing process based on the concept of a digital twin system, and realized the product design and the virtualization as well as digitization of the manufacturing process by simulating all the links of the production process through simulation. The American company ANSYS Inc, which is well-known for finite element simulation, has proposed a digital twin simulation scheme based on finite element simulation and system-level simulation as the ultimate goal. At present, the digital twin system is mainly concentrated in underground space engineering, bridge engineering and water conservancy engineering. developed a three-dimensional (3D) digital twin model for the maintenance of prestressed concrete bridges based on 3D information management and a digital image inspection system. created a full life cycle sustainable digital twin system for urban underground rails. used a digital twin system to address the issues that the existing digital model of the reinforced concrete bridge could not optimally restore the bridge state.

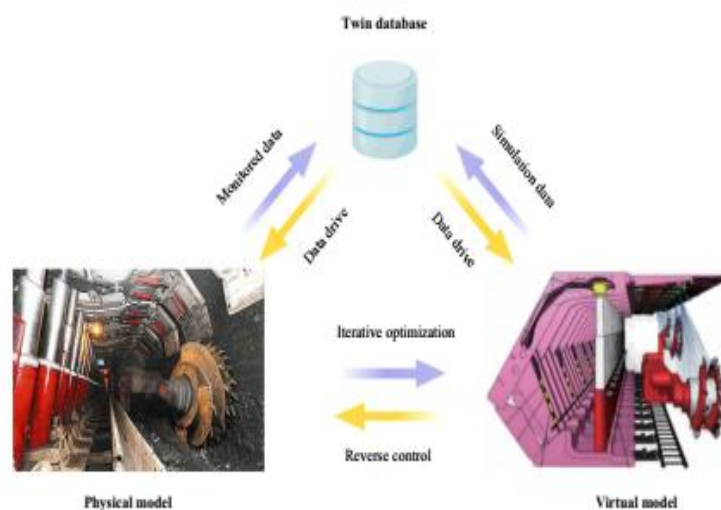

Fig. 1 Conceptual diagram of digital twin system

Published under an exclusive license by open access journals under Volume: 2 Issue: 10 in Oct-2022

Copyright (c) 2022 Author (s). This is an open-access article distributed under the terms of Creative Commons Attribution License (CC BY). To view a copy of this license, visit <https://creativecommons.org/licenses/by/4.0/>

Digital twin system is a simulation process that integrates multi-physical fields, multi-scales, and multi-probabilities. Its significant feature is the processing of massive data. The method to realize the fidelity of the data-driven model and the fusion of multi-source data is crucial to the model reconstruction. Numerous investigations have been performed to study data operation. To improve the accuracy of the estimation results, used a Kalman filter to process the numerical noise input by the sensor to improve the accuracy of the estimation results. reported that the fidelity of the digital twin model is constrained by geometry, physics and behavior rules. studied the data acquisition method of machining process of computer numerical control (CNC) machine tools and established the spatial-temporal mapping model corresponding to machining process data and part processing position. proposed a parallel configurable acquisition method of multi-source heterogeneous data based on field programmable gate array (FPGA) to ensure real-time data acquisition. To solve the problem of multi-source data fusion, proposed a multi-data source information fusion fault diagnosis method based on improved Dempster evidence theory. proposed a method for dynamic data-driven modeling and simulation of digital twin systems. The physical model and sensors in cyber-physical system (CPS) were modeled using random finite sets, and the prediction and correction process based on the Bayesian inference supported the data-driven simulation model operation. proposed the digital thread method to manage the information flow of the digital twin mining face system. The data of the information flow were divided into periodic data, random data and sudden data for modeling processing to ensure the data driven and stable operation of the digital twin mining face. In conclusion, digital twin system has been widely used in aerospace, advanced manufacturing, and other aspects, and scholars have reported considerable achievements in their scientific research. Although a few studies have reported some conceptual design in coal mining engineering , the application of digital twin systems in the geological model reconstruction in the underground coal mining industry has not been reported in the open literature. The majority of digital twin system introductions in mining engineering are focused on designing mining machinery systems such as coal mining machines, coal resource transport systems, and monitoring systems. The accurate reconstruction of large-scale multi-physical field models in the space of complex geological structures is the foundation of coal mining safety. Although some achievements have been made in multi-source data fusion, the collection and transition of multi-physical field data pertaining to fault geological conditions are still the key steps in model reconstruction studies. Thus, this study proposes a methodology for the digital reconstruction of complex fault structures in coal mines and facilitates the realization of the collection and transmission of multi-physical field data, based on the concept of establishing virtual models in the digital twin system.

Theoretical foundation of the interpolation algorithm.

The major concern of digital reconstruction of fault structure is identifying a method to realize the multi-physical field data visualization in three dimensions, such as the geometric structure, stress distribution, and strain variation. To create a detailed visual model, obtaining accurate data for all positions the model is theoretically necessary. However, owing to acquisition method and cost constraints, only a few discrete and limited datasets reflecting distribution characteristics are obtained. Therefore, the continuous distribution and evolution of multi-physical field data should be obtained through spatial interpolation. Current interpolation applications are primarily focused on one and two dimensions, with the corresponding attributes being interpolated based on plane coordinates. For example, selected the inverse distance weight to interpolate the stratum elevation to generate geological entities. proposed a method of gas concentration field reconstruction based on a spatial-temporal semi-variogram. Li and developed a new spatial interpolation method considering the influence of terrain to interpolate rainfall information. However, because the aforementioned methods cannot reflect the attribute distribution of 3D space, a 3D multi-physical field interpolation method is

proposed to realize the digital reconstruction of multi-physical fields of fault structure mines. The proposed method is applicable to any data in the multi-physical fields investigated in this study. Using strain data as an example, the specific implementation steps can be divided into the following four steps. Step 1: Arrangement of monitoring sensors. Several planes with number of k are considered from the z direction of the studied model, and a set of strain sensors with m rows and n columns are arranged on each plane, as shown in Fig. 2. Step 2: Calculation of strain distribution in one dimension. The Lagrangian interpolation is a polynomial interpolation method. Its implementation principle involves construction of a higher order polynomial through multiple sampling points to predict unknown points. Owing to its neat structure and convenience of characterization, it has been widely used in linear interpolation.

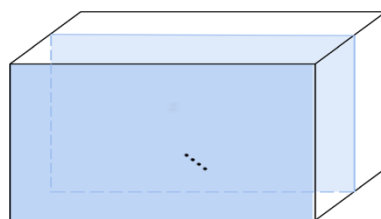

Fig. 2 Arrangement of monitoring sensors used for the interpolation algorithm

To construct the Lagrangian function, an interpolation basis function is constructed first as follows:

$$l_i(x) = \frac{(x - x_1) \cdots (x - x_{i-1})(x - x_{i+1}) \cdots (x - x_n)}{(x_i - x_1) \cdots (x_i - x_{i-1})(x_i - x_{i+1}) \cdots (x_i - x_n)}$$

where $l_i(x)$ is the interpolation basis function along the x direction and x_i is the x-coordinate of the i point that has been monitored, $i \in [1, n]$. Based on Eq. (1), the row strain interpolation function is obtained by fitting the strain components measured in each row of monitoring sensors on the k plane and can be written as follows:

$$\epsilon(x) \Big|_{y=y_j} = \sum_{i=1}^n l_i(x) \epsilon_{x_i}$$

where y_j is the y-coordinate of arbitrary row, $j \in [1, m]$ and ϵ_{x_i} is the strain value at x_i point in j row of k plane. Similarly, the column strain interpolation function is obtained by fitting the strain components measured in each column of monitoring sensors on the k plane and can be written as follows:

$$\epsilon(y) \Big|_{x=x_i} = \sum_{j=1}^m l_j(y) \epsilon_{y_j}$$

Based on the calculated results obtained using Eqs. (2) and (3), the strain distribution in one dimension along x and y directions can be obtained, respectively. Step 3: Calculation of strain distribution in two dimensions. The Shepard interpolation is a plane interpolation method, and it is called the inverse distance weighted method. The weighted average value of the known point coordinates is used to calculate the interpolation point assignment value, and the weight function is defined as inversely proportional to the distance. Based on the Shepard interpolation method and strain interpolation functions obtained in one dimension, the strain interpolation functions of arbitrary plane can be written as follows:

$$\varepsilon(x, y) = \begin{cases} \frac{\sum_{q=1}^n r_q \left(\frac{1}{r_q}\right)^u}{\sum_{q=1}^n \left(\frac{1}{r_q}\right)^u} & r_i \neq 0 \\ \varepsilon_{ij} & r_i = 0 \end{cases}$$

where $r_i = \sqrt{(x - x_i)^2 + (y - y_i)^2}$ is the distance from the monitored points to the interpolation points; ε_{ij} is the strain values at the intersection of row j and column i of arbitrary plane; and u is the weight index. Step 4: Calculation of strain distribution in three dimensions. In this study, the one- and two-dimensional interpolation have been used in an arbitrary plane. The Lagrangian interpolation method will be used to perform 3D interpolation based on several interpolated planes. Therefore, 3D interpolation can be combined with two-dimensional and one-dimensional interpolation. The 3D space is divided into several horizontal layers in the vertical direction. First, each interpolated plane has been determined as the scatter group in z direction. Then, Lagrangian interpolation is performed along the z direction of the interpolated planes. Based on the aforementioned method, the 3D strain function of the studied model can be determined as follows:

$$\varepsilon(x, y, z) \Big|_{(x=x_i, y=y_j)} = \sum_{q=1}^k l_q(x, y) \varepsilon_{z_q}$$

where $l_q(x, y)$ is the interpolation basis function in z direction, $q \in [1, k]$ and ε_{z_q} is the strain value at plane k .

Digital reconstruction scheme of fault structures

The digital reconstruction does not refer to a simple construction of the fault geometry. However, it is a comprehensive reproduction of multi-physical field data of fault structure. The digital reconstruction scheme is expected to have the following four steps.

Collection and fidelity of multi-physical field data of fault structures

Multi-physical field data of fault structures include the fault geometry data, composition and parameters of overburdened rock masses, in situ stress distribution, and boundary conditions. Notably, the fidelity of in situ stress and boundary conditions is crucial in the digital reconstruction of fault structures. In this study, considering the high cost of data collection, the large scale of the fault structures in underground coal mines, and the uncertainty of complex geological conditions, a physical model with the fault structures under the laboratory environment is initially constructed. Figure 3 presents the schematic of multi-physical field data collection and fidelity in a laboratory setting. The collection of multi-physical field data is mainly based on the geophysical monitoring methods, including seismic high-power geological radar, wave advanced detection, transient electromagnetic detection, and the borehole stress relief method for in situ stress. High-power geological radar can detect and obtain the location coordinates, fault throw, and dip angle of the complex fault structures from the ground surface to an underground roadway or a mining face. These geometrical parameters are the main data for the geometric morphology fidelity of the fault structures under laboratory conditions. The wave advanced detection method is used to determine the composition of overburdened rock masses and as well as to provide data for the fidelity of rock strata distribution. Transient electromagnetic detection can confirm the hydrological environment near the faults and determine whether water fidelity should be implemented within the physical model of the fault structures. The borehole stress relief method is the main method to detect in situ stress around the fault

structures. In this study, based on the borehole stress relief method, a new dynamic stress monitoring system will be developed. This system can monitor in situ stress, mining-induced stress, and tectonic stress. This system comprises borehole stress sensors, a data terminal integrator, data analysis software, and image processing software, as shown in Fig. 4. The boundary conditions of the fault physical model can be established in the laboratory using detection data from the dynamic stress monitoring system. The fidelity of the stress boundary condition is realized by developing an adaptive boundary pressure propulsion device, establishing a data interface with the stress monitoring system, and autonomously applying a stress boundary condition similar to that of the in-situ stress of the coal roadway.

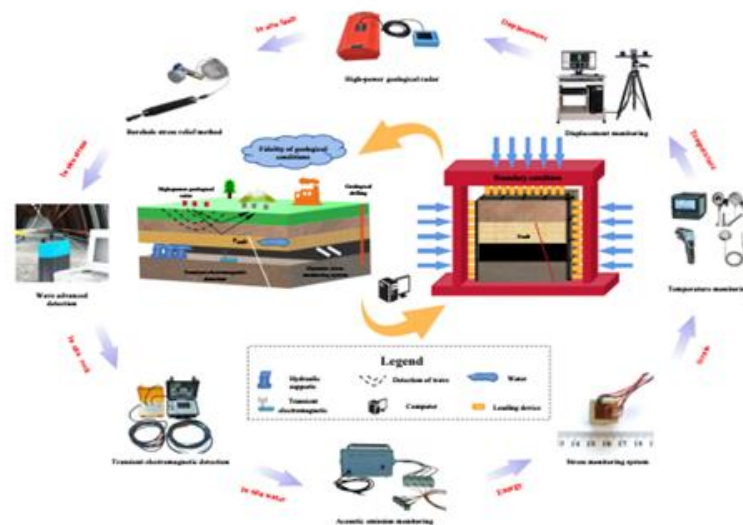

Fig. 3 Schematic of multi-physical field data collection and fidelity

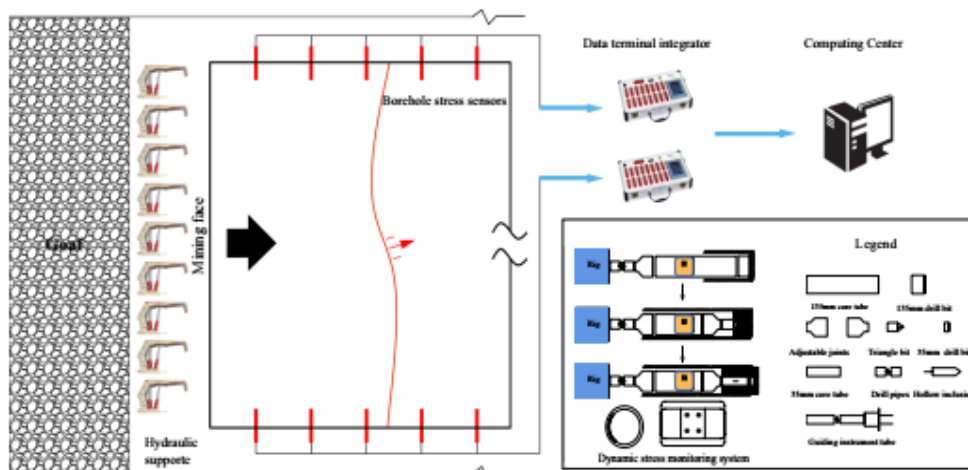

Fig. 4 Dynamic stress monitoring system

Based on the deep engineering failure simulation system, the overburden rock mining-induced stress monitoring system, fault tectonic stress monitoring system, overburden rock displacement monitoring system, dynamic scanning system of the ground-penetrating radar for the internal structure of the overburden rock, and full-information acoustic emission signal analysis system are connected. The above systems are used to collect data from overlying rock mining stress field, overlying rock movement displacement field and fault sliding stress field, which serves as the foundation for digital reconstruction. Although the more sensors are installed on the physical model with a definite size, the

more accurate the monitoring results will be. Installing excess sensors is not recommended. The presence of numerous embedded sensors will cause stress concentration in the physical model, influencing the experimental results. Therefore, the sensor layout must be determined based on the test conditions.

Transmission of multi-physical field data

The collection of multi-physical field data poses a challenge to the massive data transmission in the physical model.

Ensuring the efficient transmission of massive amounts of data is a critical step toward realizing the digital reconstruction of complex fault structures. The following two modules should be prioritized for efficient transmission of multiphysical field data from physical model to digital model: the data interface module for real-time data interaction and the parallel algorithms module for data sharing, fusion, and integration. Figure 5 presents the process of multi-physical field data transmission. The first module is to be established as the data interface for dynamic real-time interaction of multi-physical field data for a physical model to the database. Using a high-speed, high-stability, and low-latency data transfer protocol, realtime dynamic data of multi-physical field sensors, such as geometric shape, displacement field, stress field, and energy field, are extracted from physical models in a unified manner. The second module will be developed as a high-performance parallel algorithm of data dynamic sharing, fusion, and integration that will be used to transmit information from the physical model to the digital space. The algorithm can automatically identify data types, automatically coordinate the allocation of resource nodes, reduce data redundancy, and ensure the high efficiency as well as timeliness of data transmission.

Multi-physical field data normalization

The normalization of multi-physical field data mainly refers to the generalization, organization, coding, and storage of stress, strain, and acoustic emission data, and the process is shown in Fig. 6. The data generalization is to preprocess the data, realize the rapid extraction of data features, and convert the original data of different formats into the unified format. The data organization is to assign coordinate information to data from different sources to form the standardization of spatial-temporal information, check data quality, and filter data that do not meet requirements. The data coding catalogs

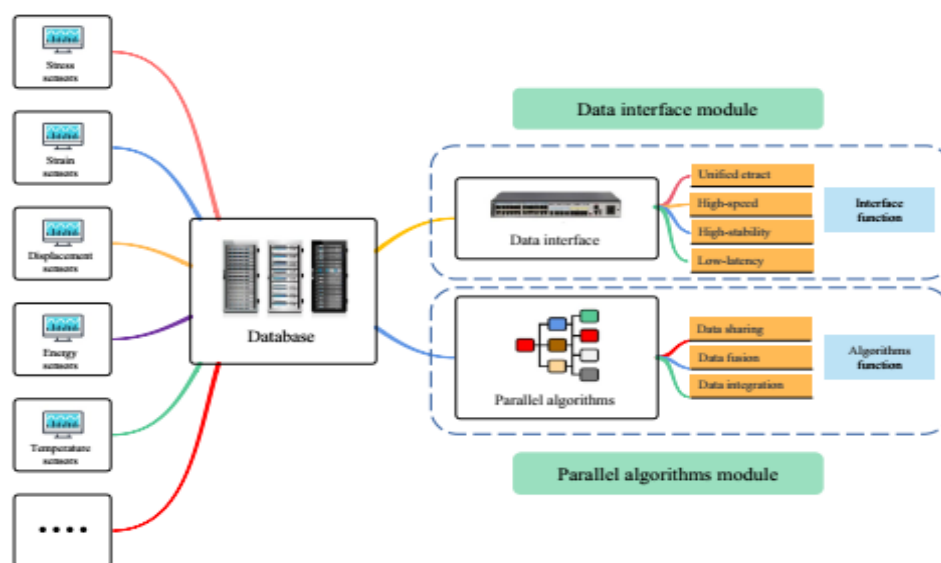

Fig. 5 Multi-physical field data transmission

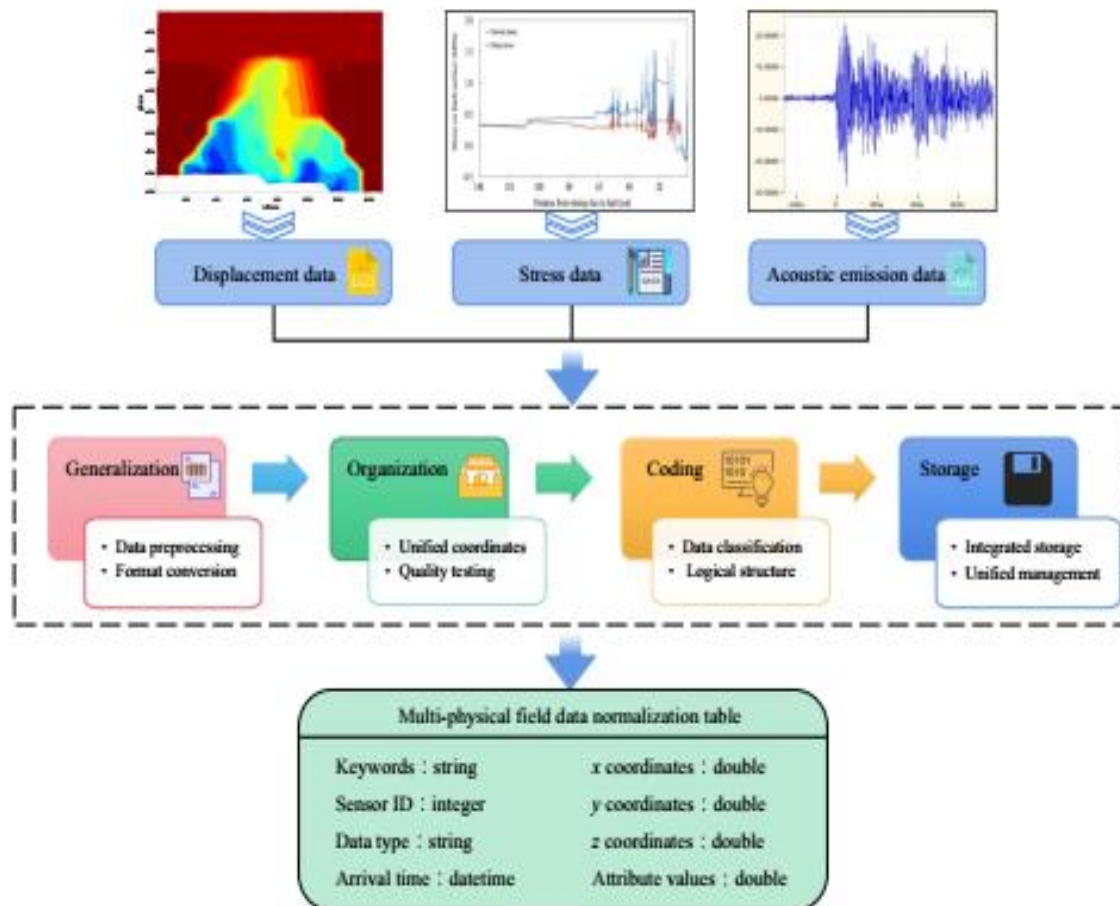

Fig.6 Schematic of multi-physical field data normalization

the processed data, designs the logical structure according to the attributes and characteristics of the data, correlate each data with serial numbers, and pack the file data into blocks after encoding to prepare for data storage. The purpose of data storage is to integrate processed data into a database so that it can be managed, transmitted and extracted uniformly. After completing the preceding four steps, the data structure database of mining history and operation state in full-time domain, full factor, and global evolution process is established. The fields in the table contain sensors number, coordinates, arrival times and physical field attribute information, as shown in Fig. 6.

Digital model reconstruction of fault structures

Based on the collection, transmission, and normalization of the multi-physical field data, the digital reconstruction of fault structure is the digitalization of multi-physical dynamic data, rather than the traditional numerical modeling. The fault structure digital model includes fault images, stress data, displacement data, drilling data, and energy data. Multi-physical field data are correlated, fused, rendered, and presented in an integrated manner via the modular integration platform, providing people with a complete observation perspective in time and space. Aiming at the complex structure location that is difficult to observe in the physical system, the problem can be solved through multi-source data interpolation and inverse fitting; hence, the system can support the in-depth observation of the operating state of the system. The system can track real-time data, historical data, and the operational status of the physical model to form a low-latency and high-fidelity mirror relationship. As illustrated in Fig. 7, the digital reconstruction of fault structure can be divided into three steps. Step 1: Based on the fault structure parameters and borehole data extracted from the database, the original data

or discrete data interpolation and fitting method are derived to reconstruct the 3D visual static geological model.

Step 2: Based on the collected multi-physical field data, the two-dimensional and 3D interpolation fitting algorithm of complex geophysical field is studied to restore the unmonitored multi-physical field data distribution.

Step 3: According to the coordinate and time information, the interpolated multi-physical field data is synchronously restored to the static geological model and the 3D cloud map is automatically generated to realize the visualization of multi-physical fields in the mining process of the mining face.

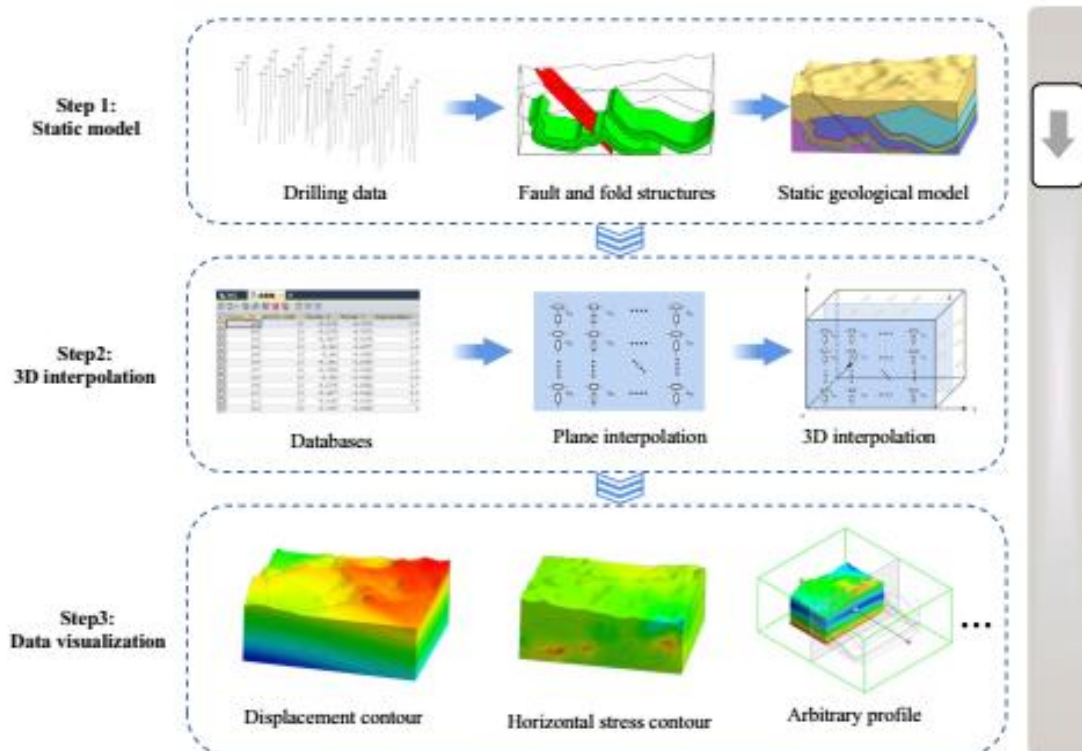

Fig. 7 Major processes of digital reconstruction of fault structures

The fault structures model can generate dynamic 3D cloud images and have the functions of zooming, rotating, cutting at any position, and data extraction, which is convenient for users to observe the target object in depth.

The key scientific issues to be resolved

Fidelity of multi-physical field data

Considering the complex geological conditions, a physical model of the fault structures is explored and constructed under laboratory conditions. The fidelity of multi-physical field data is primarily determined using the fault structures geometry, overburdened rock mass composition, in situ stress distribution, and boundary conditions. Therefore, in this study, high-sensitivity and high-precision sensors, an adaptive boundary pressure propulsion device, and a multiscale simulation test platform are developed. The high-precision sensors can monitor the in situ stress data in real time, and the adaptive boundary pressure propulsion device can realize the adaptive pressure on the boundary of the model according to the collected stress data. The structure of the platform is shown in Fig. 8. The experimental platform comprises a base, left and right plates, and an upper roof. The side plates and roof are outfitted with multiple evenly distributed pressure heads, allowing for the model's seamless

Published under an exclusive license by open access journals under Volume: 2 Issue: 10 in Oct-2022

Copyright (c) 2022 Author (s). This is an open-access article distributed under the terms of Creative Commons Attribution License (CC BY). To view a copy of this license, visit <https://creativecommons.org/licenses/by/4.0/>

loading under computer and servo-hydraulic control system control. The upper and right plates are free to move, allowing for multi-scale modeling. A new dynamic stress transmission algorithm is developed to automatically identify, filter the error data, and convert the boundary loads, which can realize the transmission and fidelity of the boundary stress data.

Normalized programming of multi-source data

Digital reconstruction of fault structure requires effective fusion of multi-physical field data. However, owing to differences in data collection sensors, time scale, and error accuracy, the normalization of multi-physical field data is the basement of data transmission and centralized presentation. Therefore, investigating the normalization programming algorithm of multi-source heterogeneous data is critical. The algorithm's main idea is mainly embodied in four steps: generalization, organization, coding, and storage. The detailed process is shown in Fig. 9. Based on a parallel algorithm, a normalized algorithm is developed to extract characteristic parameters of multisource data, filter redundant data and distribute coordinate information of monitoring points automatically. The data logical structure is designed based on the data relationship. Finally, the database with multi-source data normalized structure is created. The normalized data can be managed, transmitted, and extracted uniformly through the database, providing a data basis for future digital reconstruction.

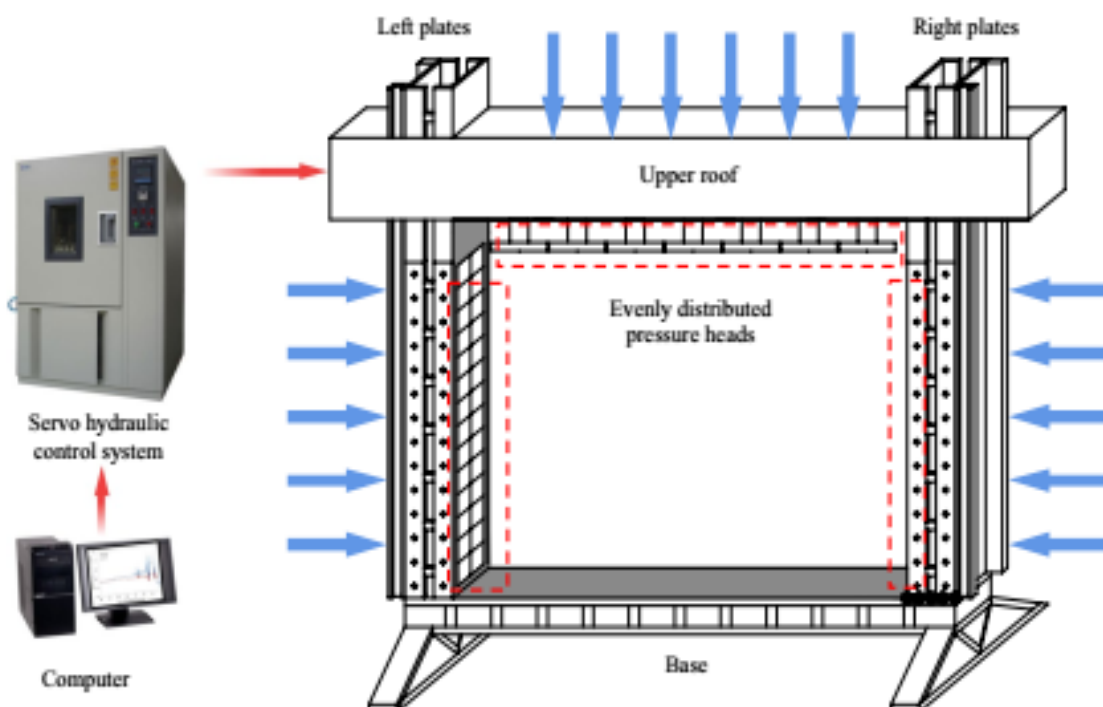

Fig. 8 Structure of multi-scale simulation test platform

Establishment on the digital model of geological structures

Based on the geological data such as borehole, geological section, and contour line collected in-site, the applicability of various interpolation algorithms in the mining area is compared and analyzed. Finally, because of its low error, the Kriging algorithm is selected as the best method. The interpolation method was used to encrypt the elevation data of different layers, and the data were imported into Midas to create DEM surfaces of the ground and strata. Based on the geological profile and geological topographic map, the main geological parameters of the fault, such as spatial position, length, drop, dip angle, and fault plane were extracted. Finally, according to the generated DEM plane,

Published under an exclusive license by open access journals under Volume: 2 Issue: 10 in Oct-2022

Copyright (c) 2022 Author (s). This is an open-access article distributed under the terms of Creative Commons Attribution License (CC BY). To view a copy of this license, visit <https://creativecommons.org/licenses/by/4.0/>

fault plane, and boundary constraint, the block model is cut to build a 3D visual static geological model of fault structure. To verify the effectiveness of the 3D visual digital geological model, the original geological profile and borehole data are combined to conduct a comparative study with the 3D visual digital model, as shown in Fig. 12. The 3D visual digital geological model constructed in this study roughly comprises geological information expressed from the main section view and side section view, confirming the accuracy of the modeling. Through the normalization processing of the collected multi-physical field data, a structured database is established in the database software SQL. Based on the Lagrangian and Shepard interpolation methods, the 3D interpolation fitting processing of the data was realized. In this study, the in-situ stress data from the Da’anshan coal mine were used to validate the proposed interpolation algorithm and the calculated and measured in situ stress values of four monitoring points at different depths were selected for error analysis and comparison. The results are listed in Table 1. The error is equal to the calculated stress minus the measured stress.

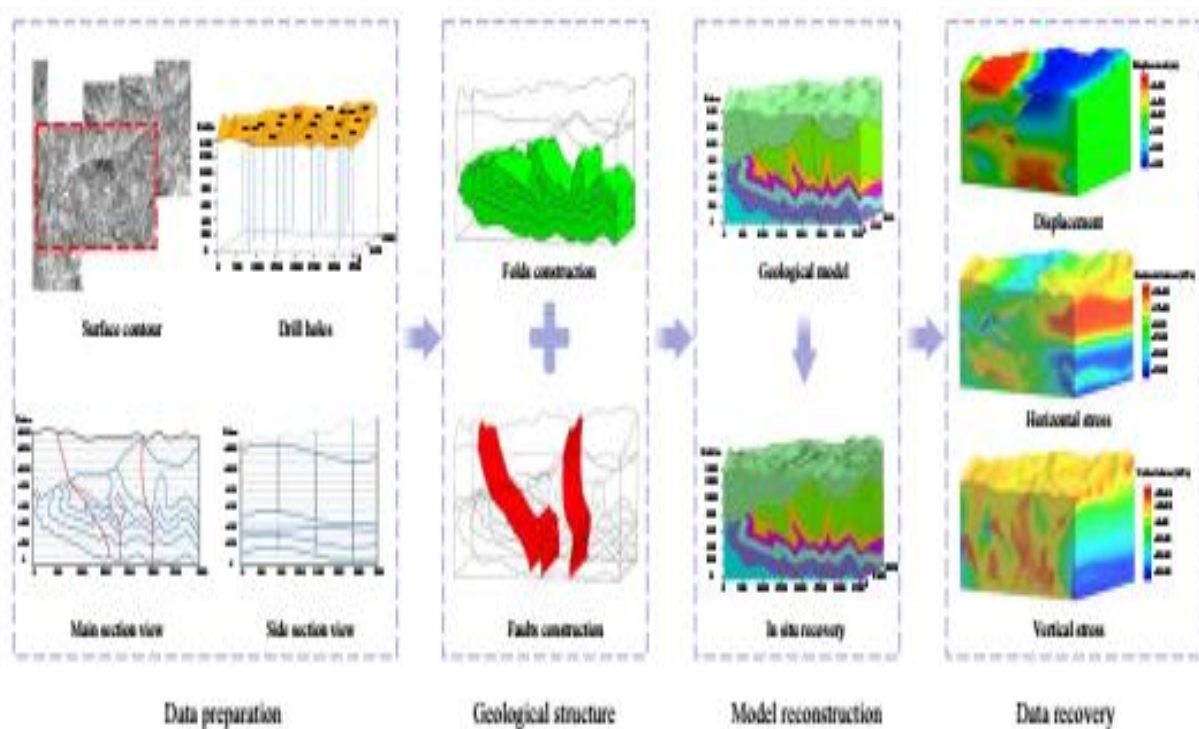

Fig. 12 Digital reconstruction results of tectonic structures in the Da’anshan coal mine

Conclusions

(*) The first key scientific issue for digital reconstruction of fault structures is to ensure the fidelity of the multiphysical field data. To collect multi-physical field data around the zone of fault structures, seismic high-power geological radar, wave advanced detection, transient electromagnetic detection, and borehole stress relief method for in situ stress are used. To apply the fidelity stress boundary conditions, a new dynamic stress monitoring system with an adaptive boundary pressure propulsion device is used.

(*) The second key scientific issue for digital reconstruction of fault structure is to realize normalized programming of multi-source data. This study develops a normalized algorithm to extract characteristic parameters of multi-source data, and filter redundant data, and automatically distribute coordinate information of monitoring points based on a parallel algorithm and interpolated calculation of strain distribution in three dimensions. According to the data relationship, this study designs the

data logical structure and establishes the multi-source data normalized structure database, which provides a data basis for later digital reconstruction.

(*) According to the geological conditions in Da'anshan coal mine in the mining area of western Beijing, China, a full-scale and 3D visual digital model which can restore the fault geological structure and the stress and displacement distribution is established. The work discussed in this study was limited to the development of a digital fault model and the representation of stress and displacement distributions in static. The related data transmission and programming to realize dynamic data visualization need to be further studied.

References

1. Ahlborn M, Stemmerik L, Kalsto TK (2014) 3D seismic analysis of karstified interbedded carbonates and evaporites, Lower Permian Gipsdalen Group, Loppa High, southwestern Barents Sea. *Mar Pet Geol* 56:16–33
2. Arkadii S (2020) Algebra for applications. Springer, Cham, pp 1–39 Belk RW (2013) Extended self in a digital world. *J Consum Res* 40(3):477–500
3. Casallas-Moreno KL, González-Escobar M, Gómez-Arias E, Mastache-Román EA, Gallegos-Castillo CA, González-Fernández A (2021) Analysis of subsurface structures based on seismic and gravimetric exploration methods in the Las Tres Vírgenes volcanic complex and geothermal field, Baja California Sur. *Mex Geotherm* 92:102026
4. Chen P, Deng F, Liu ST (2015) Research on 3D spatial property interpolation method. *Comput Knowl Technol* 11(7):235–239
5. Chen SJ, Li ZY, Ren KQ, Feng F, Xia ZG (2020) Experimental study on development process of reverse fault in coal measures strata and law of stress evolution in hanging wall strata. *J Min Saf Eng* 37(02):366–375
6. Feng B, Chen MT, Yue DD, Li ST, Jia XF, Song D (2019) Comparison of 3D geological modeling based on two different interpolation methods. *J Jilin Univ (earth Sci Ed)* 49(04):1200–1208 Ge SR, Zhang F, Wang S (2020) Digital twin for smart coal mining workface Technological frame and construction. *J China Coal Soc* 45(6):1925–1936
7. Guo CX, Peng MW, Liu Y (2009) Novel Approach for Fault diagnosis of the power Grid with information fusion of multi-data Resources. *Proc CSEE* 29(31):1
8. Higham NJ (2004) The numerical stability of barycentric Lagrangian interpolation. *IMA J Numer Anal* 24(4):547–556